



## FDR D-EVO™ Suite II

### *Integrated Digital Radiographic Solutions*

#### **Application:**

The FDR D-EVO Suite II is a complete integrated digital X-ray room replacement system, highlighted with new flexibility and safety features. A completely scalable solution, the D-EVO Suite II is configurable for any general radiology application and budget. It can be used with any of the latest FDR D-EVO detectors, all of which feature exclusive ISS technology designed to minimize light scatter to capture sharper signals at lower doses. The integrated FDX Console, with its customizable user interface, provides a simple and efficient workflow that utilizes SpeedLink X-ray control software to automate exam menu mapping, and Dynamic Visualization image processing, auto trimming, precise enlargement and other imaging benefits.

#### **Configurations:**

This next-generation DR Suite, available as a motorized or manual overhead mounted room, features SpeedLink automated techniques, auto cassette size sensing and motorized tracking of the tube head with flexible elevations of the upright or table devices. A touchscreen LCD on

the tube head allows the technologist to adjust generator settings (kV, mAs, AEC settings) at the table side leaving the patient virtually only to make the exposure.

Configurations include:

- Motorized or manual overhead mounted X-ray system with chest stand, table and single or multiple detectors (ACSS requires motorized overhead tube stand)
- Chest only system with overhead mounted X-ray, upright chest stand and single or multiple detectors. (ACSS requires motorized overhead tube stand)
- Configurable options include motorized or manual overhead, auto cassette size sensing or manual collimation, tilting or non-tilting & right or left opening chest stand and 80kW or 55kW generator system, 1/2-point or 3-point technique console.

#### **Standard Components**

##### **FDX Console**

The technologist workstation has a customizable user interface that is consistent for FCR and FDR, with dynamic visualization image processing that enhances image quality throughout the entire image, and SpeedLink

X-ray control software with automatic preset techniques to each exam menu.

##### **Detector**

The Suite is designed to be used with any of our FDR D-EVO flat-panel detectors: 14x17" or 17x17" GoS, or 14x17" CSI and future standard cassette sizes. FDR D-EVO detectors are lightweight, portable and provide preview in as little as 2 seconds and 9 seconds cycle times. The detectors feature Fujifilm's patented Irradiated Side Sampling technology (ISS) which is designed to minimize light spread to capture sharper detail with higher DQE dose efficiency.

##### **Ceiling Suspended Tube System**

The compact and versatile ceiling mounted tube crane has a 5-element telescope and gooseneck design that allows a short tube-to-ceiling-distance and will nicely accommodate rooms with low ceilings. The system features easy to reach grip handles and button locations with light and easy travel for precise positioning anywhere around the room. The sys-

# FUJIFILM MEDICAL SYSTEMS

tem's light easy grab and go positioning is perfect for routine orthopedic and critical trauma and emergency room x-ray applications. Telescope tube support extension provides additional 8" to vertical travel.

## Auto Cassette Size Sensing and Collimation

Auto Cassette Size Sensing now recognizes the 17x17" DR detector format size in the bucky device. Through X-CON/Speedlink communication, the automatic collimator configuration will adjust the illuminated exposure field size based upon specific exam type selected.

Automatic collimator incorporates the latest super bright, long-lasting LED technology and precision centering laser. Collimation light automatically activates with device positioning movements to allow fast, easy exam positioning set-up. A lamellae layer close to the radiation beam shields off extra-focal radiation, and additional pre-filters are integrated for either manual or menu driven operation. Both the current source-image distance (SID) and the size of the collimated radiation field are displayed in the LCD (except for A 01, AF 01 II). The Bucky centering light generated by the laser results in a sharp light line for all source-image distances (not A 01 II and AF 01 II).

## Generator

Available in a 3-phase 55 or 80kW versions. 600kHU tube and falling load generator for long term reliability and shorter exposure time. The system features multiple exposure control interfaces, automatic exposure control.

## Standard Control Console

Systems include a standard control

console to allow for fine tuning parameters based on the patient for 1 and 2-point techniques (or 3-point techniques with upgraded control console).

## New Touchscreen Display Interface

The motorized overhead system features our latest touchscreen LCD control at the tube head. In addition to the standard x-ray control console, all of the typical adjustments are now available at the tube head display, allowing technologist to stay with the patient and only return to the control panel to initiate the exposure.

## SpeedLink X-ray Control™

Two-way communication of automatic menu mapping and exposure data back are also integrated into the FDX Console via Fujifilm's SpeedLink X-ray Control™ software, which simplifies use of preferred parameters for every anatomic menu.

With highly accurate radiographic parameters and precise reproducibility, these generators also feature a 32-bit microprocessor and fast regulation of high voltage and tube current.

## Wall Stand Bucky

There are two wall stands to select from for fast and simple routine exams of standing or sitting patients. Available as a tilting or non-tilting vertical Bucky. The Bucky can be left or right loaded on either stand, both of which feature simple one-hand operation. Bucky is nicely counterbalanced for light, easy vertical movement. Automated collimation and tube tracking functions require the tilting model. Chest stand bucky spacer allows additional clearance for use of tilted upright with x-ray transparent gurney tables (for tilting

upright only. Requires STATIONARY GRID).

## Table

The table works seamlessly with the overhead tube system. It is a height-adjustable 4-way floating table top is ergonomically designed to eliminate sharp edges and is designed to accommodate up to 617 lbs. The table can be lowered to less than 2 feet from the floor. Float top brakes and table height adjustment are controlled with convenient vertically positioned table base toe switches. The grip handles are included and can easily be removed or repositioned.

## Options

- Single or multiple flat panel detector workflow configurations
- Motorized or manual overhead tube crane system
- 55 or 80kW generator
- Standard or touch screen console
- Fixed or tilting upright bucky, left-or right-opening
- Table top detector holder
- 4M bridge
- DAP meter
- Patient compression belt
- Telescope extension tube
- Second rear of table control toe switch
- Wall stand bucky spacer
- System can also be used with CR on demand or as a dedicated CR Room System

## Dimensions and Weight

### Upright

#### Non-tilting

37.4" l x 30" w x 82.9" h, 429lb

Vertical travel range: 15.0" to 70.9" above floor

#### Tilting

48.9" l x 30" w x 82.9" h, 517lb

Vertical travel range: 13.4" to 68.1"



# FDR D-EVO™ Suite II

*Integrated Digital Radiographic Solutions*

**Application:**

The FDR D-EVO Suite II is a complete integrated digital X-ray room replacement system, highlighted with new flexibility and safety features. A completely scalable solution, the D-EVO

the tube head allows the technologist to adjust generator settings (kV, mAs, AEC settings) at the tableside leaving the patient virtually only to make the exposure.

Configurations include:

X-ray control software with automatic preset techniques to each exam menu.

**Detector**

The Suite is designed to be used with any of our FDR D-EVO flat-panel de-

D-EVO Suite II chart

Generator Specifications	GEN RF 80 (80kW)	GEN RF 55 (55kW)
High voltage waveform Multi-pulse	*	*
Power rating (55 kW acc. IEC 60601)	1000 mA at 60 kV 800 mA at 100 kV 667 mA at 120 kV 533 mA at 150 kV	640 mA at 60 kV 550 mA at 100 kV 458 mA at 120 kV 367 mA at 150 kV
Exposure voltage 40 kV to 150 kV	*	*
<b>Automatic control</b>		
1-point technique with continuously falling load and AEC	*	*
2-point technique with constant load	*	*
<b>mAs integrator</b>		
From 0.5 mAs to 800 mAs	*	*
<b>Exposure time</b>		
1-point technique: 1 ms to 5 s with mAs-post-indication		
2-point technique: 2 ms to 5 s depending on mAs and kV	*	*
<b>Tube assembly (IT)</b>		
Adaptable to one X-ray tube assembly with two foci (max)		
Automatic exposure control IONTOMAT, 2 input channels	*	*
<b>Tolerances</b>		
kV accuracy ±5%	*	*
mAs accuracy ±5% or 0.5 mAs, whichever is greater	*	*
<b>Power line connection</b>		
3-phase	480 V +/- 10%, 50/60 Hz	480 V +/- 10%, 50/60 Hz
<b>Line impedance</b>		
400v	0.11 Ohm (400 V)	0.17 Ohm (400 V)
440v	0.14 Ohm (440 V)	0.20 Ohm (440 V)
480v	0.16 Ohm (480 V)	0.24 Ohm (480 V)
<b>Ambient conditions during operation</b>		
Temperature range: + 10°C to 40°C	*	*
Rel. humidity: 20% to 75%, above dew point	*	*
Barometric pressure: 70 kPa to 106 kPa	*	*
Weight Cabinet: High-voltage transformer 422	*	*
Control Console: approx. 3.3lbs.	*	*

## Overhead Tube Crane System

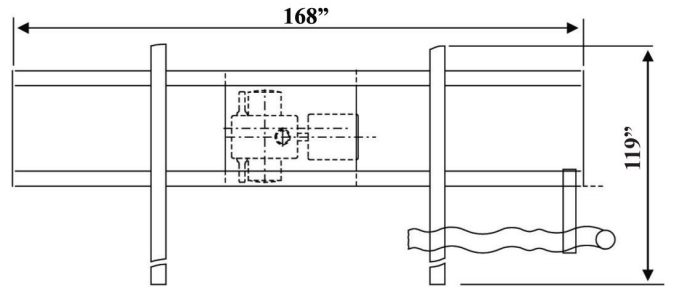
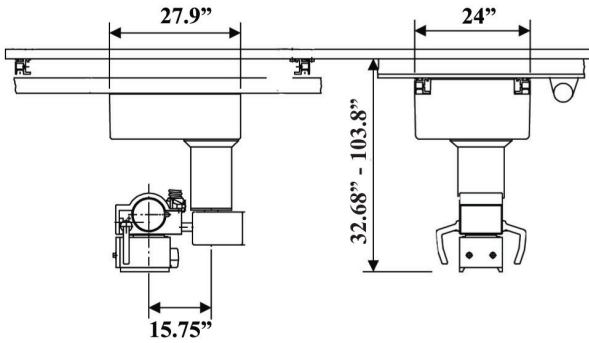

### Table (front)

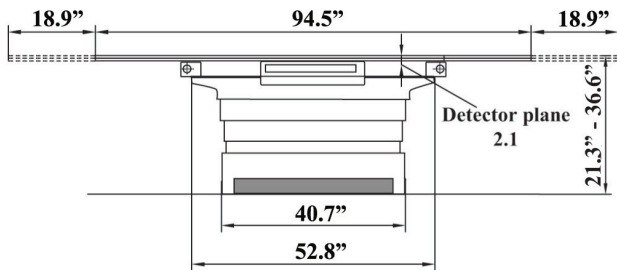

### Table (top)

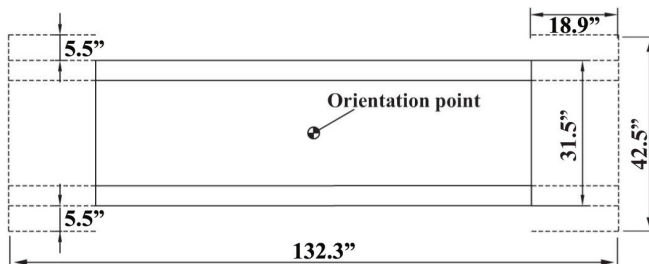

### Upright

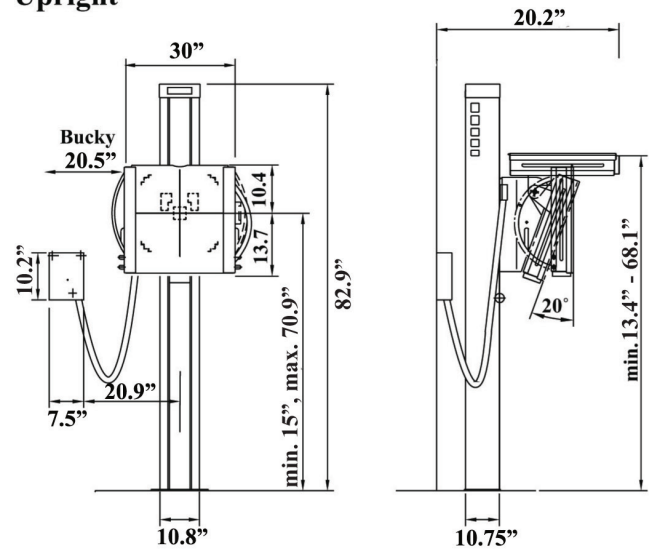

### Also includes

**Generator cabinet: 40.2x21.6x21"**

**Generator console: 3x10x11"**

## FUJIFILM Medical Systems USA, Inc. Corporate Headquarters

419 West Avenue  
Stamford, CT 06902-6348  
866-879-0006  
www.fujimed.com

© 2016 FUJIFILM Medical Systems U.S.A., Inc.

# FUJIFILM

XBUSDR079-A